

# Manual Food Slicer

Model : WFS35MGB3

Versatile manual food slicer featuring a 350 mm diameter blade and excellent features including a blade safety ring and salami holder. Ample operator access for fast, safe clean up of food debris behind the blade. Ideal for New Zealand Supermarkets and Butchers.

## FEATURES

- large 3rd generation 350 mm blade, with low-friction cutting edge for precise low-force slicing
- high capacity carriage for extra large cuts of meat
- stow-away product holder for slicing flexibility
- patented Poly-V belt drive with automatic tensioner - NO belt slippage
- extremely quiet and smooth drive system
- salami holder: an additional adjustable "fence" to keep round products stable when slicing
- external sharpener: safe, effective and always at hand to regularly sharpen the blade
- ample operator access for fast cleanup of food debris behind blade
- attractive highly polished aluminium alloy construction allows easy cleaning and better hygiene
- single phase 240 V AC 50 Hz
- net weight 35 kg



## SAFETY FEATURES

**Blade safety ring:** the blade is completely shrouded by a metal safety guard.

**Safety interlock:** the carriage interlock does not allow tilting of the carriage unless the index knob is set to zero. This prevents the blade from being exposed whilst cleaning, thereby reducing risk of injury.

**Power fail safe:** if mains power fails and is resumed, the slicer will not start until the slicer "on" button is re-selected by the operator. There is no risk of the slicer starting inadvertently.

**No blade removal required:** a large gap between the blade and motor housing allows easy access behind the blade for cleaning. There is no need for an operator to remove the blade.

**CE Approved:** this means the highest standards of design and manufacture have been adhered to for optimal level of safety for the user.

## SPECIFICATIONS

Model Number	Blade Diameter (mm)	Slice Thickness (mm)	Overall Dimensions (mm)
WFS35MGB3	350	0 - 25	610 (W) x 778 (D) x 656 (H)

Specifications may change without notice

## FOOD EQUIPMENT

# Manual Food Slicer

Model : WFS35MGB3

## ADDITIONAL SPECIFICATIONS

### PRODUCT CAPACITY (mm)

Maximum Product Diameter	260 Ø
Maximum Slice Thickness	25

### DIMENSIONS (mm)

Blade Diameter	350
Footprint	450 (W) x 590 (D)
Working Area Required	610 (W) x 800 (D)

Motor	IP65 rated water resistant
Switches	IP69 rated water resistant

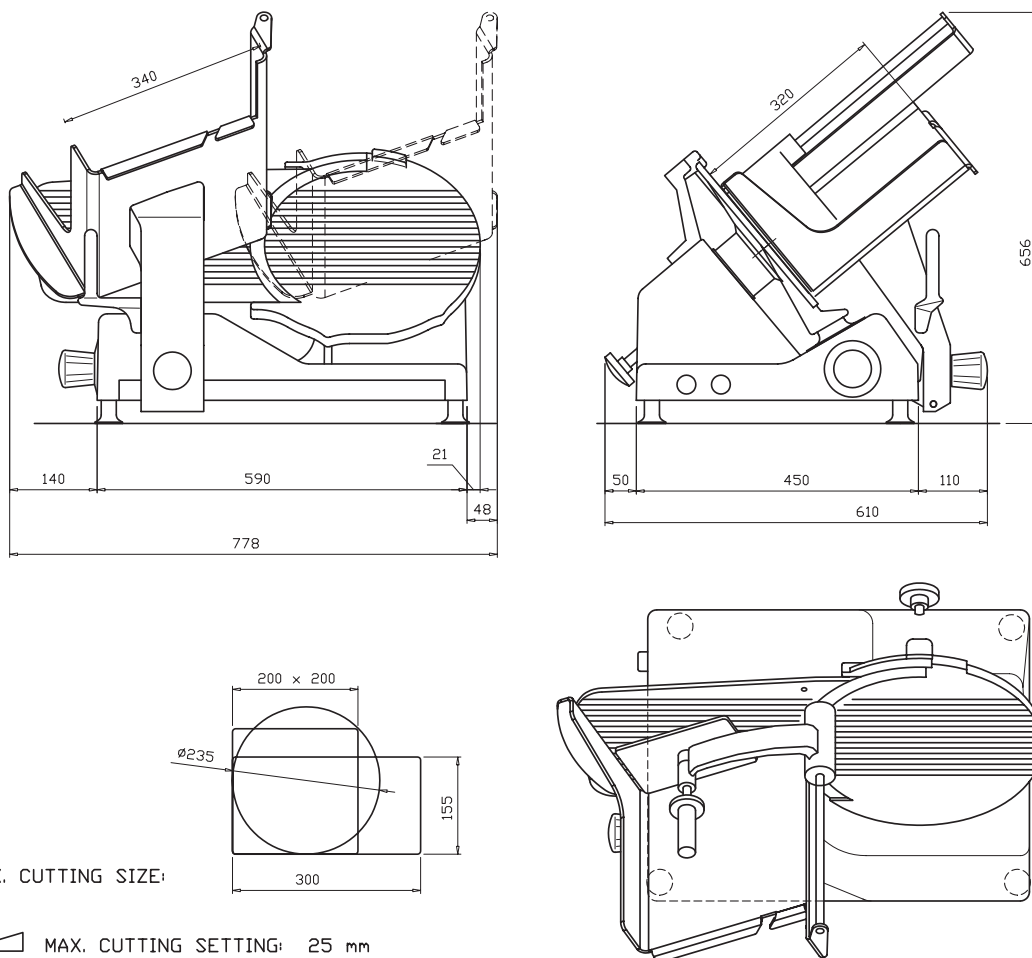

Specifications may change without notice

## FOOD EQUIPMENT

LABELS | LABELLING EQUIPMENT | PACKAGING EQUIPMENT  
ESL & DIGITAL SIGNAGE | WEIGHING SCALES | POS SYSTEMS  
FOOD EQUIPMENT | MAINTENANCE & REPAIRS | HIRE

0800 800 379  
enquiries@wedderburn.co.nz  
www.wedderburn.co.nz